

specifications

Category 5e/Class D, 8-position, UTP jack module shall terminate 4-pair, 22-26 AWG, 100 ohm unshielded twisted pair cable and shall not require use of a punchdown tool. UTP jack modules shall use a forward motion termination method to optimize performance by maintaining cable pair geometry while eliminating conductor untwist. The termination cap shall be color-coded red to designate Category 5e performance and shall include a universal label coded for T568A and T568B wiring schemes.



technical information

Category 5e/Class D channel and component performance:	Exceeds channel requirements of ANSI/TIA-568-C.2 Category 5e and ISO 11801 Class D standards at swept frequencies 1 to 100 MHz Exceeds component requirements of ANSI/TIA-568-C.2 Category 5e and ISO 11801 Class D standards at swept frequencies 1 to 100 MHz
FCC and ANSI compliance:	Meets all applicable ANSI/TIA-968-A requirements; contacts plated with 50 microinches of gold for superior performance
IEC compliance:	Meets IEC 60603-7
RoHS compliance:	Compliant
PoE compliance:	Meets requirements of IEEE 802.3af and IEEE 802.3at for PoE applications
UL rated:	UL 1863 approved
Conductor termination range:	Wire cap compatible with 22-26 AWG solid or stranded cable with conductor insulation diameters of 0.060 in. max. and overall cable O.D. 0.200 in. to 0.330 in.

key features and benefits

100% performance tested	Confidence that each jack module will deliver the critical electrical performance requirements
Utilizes enhanced Giga-TX™ Technology	Optimizes performance by eliminating conductor untwist and reduces installation time and expense
Improved termination cap	Conductor retention slots simplify jack module termination
Modular	UTP jack modules snap in and out of all Mini-Com® Faceplates, Modular Patch Panels and Surface Mount Boxes for easy moves, adds, and changes
True strain relief	Controls cable bend radius for long-term installed performance
Individually serialized	Marked with quality control number for future traceability
RJ45 interface	Industry standard interface provides a quick and easy plug and play connection to RJ45 patch cords; backwards compatible
Identification	Can be clearly identified with optional labels and icons for port Identification
Keyed version available	Color-specific keys with positive and negative keying features mechanically and visually distinguish connections to prevent unintentional mating with unlike keyed or non-keyed modular plugs, offering network design flexibility, versatility, accommodating discrete networks for enhanced security
Termination tools (optional)	EGJT termination tool ensures conductors are fully terminated by utilizing a smooth forward motion without impact on critical internal components for maximum reliability; TGJT termination tool ideal for high volume installations
Block out device (optional)	Provides a simple and secure method to control access to data ports while not in use
Shuttered version (optional)	Integrated shuttered door keeps out dust and debris of unmated RJ45 jack modules

applications

Mini-Com® TX5e™ UTP Jack Modules are a component of the TX5500™ UTP Copper Cabling System. This end-to-end system provides Gigabit Ethernet performance with usable bandwidth beyond 100 MHz. With certified performance to the ANSI/TIA-568-C.2 Category 5e and ISO 11801 Class D Edition 2.1 standards, this system will support the following applications:

- Ethernet 10BASE-T, 100BASE-T (Fast Ethernet), 1000BASE-T (Gigabit Ethernet)
- 155 Mb/s ATM, 622 Mb/s ATM
- Token ring 4/16
- Voice/data systems
- Voice over Internet Protocol (VoIP)

www.panduit.com

TX5500™ UTP Copper Cabling System

Mini-Com® TX5e™ UTP Jack Modules

Jack module:	CJ5E88TGIW*
Shuttered jack module:	CJD5E88TGIW*
Keyed jack module:	CJK5E88TG**

TX5500™ UTP Copper Cable

Plenum:	PUP5504***
Riser:	PUR5504***
LSZH:	PUL5504***
CM:	PUC5504***

TX5e™ UTP Patch Cords

CM (foot lengths):	UTPCH^Y
CM (meter lengths):	UTPCH^MY
LSZH (meter lengths):	UTPCHL^MY

Mini-Com® Angled Modular Patch Panels

24-port, 1 RU:	CPPLA24WBLY
48-port, 2 RU:	CPPLA48WBLY

Mini-Com® Flat Modular Patch Panels

24-port, 1 RU:	CPPL24WBLY
48-port, 2 RU:	CPPL48WBLY

For additional modular patch panels and punchdown patch panels, visit www.panduit.com

Tools and Accessories

Jack module termination tool:	EGJT or TGJT
Wire snipping tool:	CWST
Wire stripping tool:	CJAST
Clear dust cap:	MDC-C
Blockout device:	PSL-DCJB-^^
Phone icons:	CIPIW-C+
Data icons:	CIDIW-C+

*To designate color other than IW (Off White), replace IW suffix with EI (Electric Ivory), IG (International Gray), AW (Arctic White), BL (Black), BU (Blue), RD (Red), YL (Yellow), GR (Green), OR (Orange), or VL (Violet).

**To designate color, add suffix BL (Black), BU (Blue), RD (Red), YL (Yellow), GR (Green), or OR (Orange). Each color representing a different keyed configuration.

***To designate color, add suffix BU (Blue) or WH (White). For additional cable colors, contact customer service.

^For lengths 1 to 20 feet (one foot increments) and 25, 30, 35, 40 feet, change the length designation in the part number to the desired length. For standard cable colors other than Off White, add suffix BL (Black), BU (Blue), RD (Red), YL (Yellow), GR (Green), OR (Orange), or VL (Violet). For example, the part number for a blue 15-foot patch cord is UTPCH15BUY.

^^For lengths 1 to 10 meters (one meter increments) and 0.5, 1.5, 2.5, 15, 20, 25, 30, 35, 40 meters, change the length designation in the part number to the desired length. For standard cable colors other than Off White, add suffix BL (Black), BU (Blue), RD (Red), YL (Yellow), GR (Green), OR (Orange) or VL (Violet). For example, the part number for a blue 15-meter patch cord is UTPCH15MBUY.

^^^To designate color other than Red, add suffix Black (BL), Blue (BU), Yellow (YL), Green (GR), Orange (OR), Off White (IW) or International Gray (IG) at the end of the part number. 10/package.

+To designate color other than IW (Off White), replace IW with EI (Electric Ivory), IG (International Gray), BL (Black), BU (Blue), RD (Red), YL (Yellow), GR (Green), OR (Orange), or VL (Violet) in the part number. 100/package.

Contact customer service for bulk packaged and/or keyed jack modules and patch cords.

Mini-Com® TX5e™ UTP Jack Modules

Test Results

Mechanical Test	Test Method	Measurement	Typical Test Results
Normal Force	—	Load (grams)	>100
Vibration	IEC 512-6d	Circuit Resistance (mOhms)	<40
Shock	IEC 512-6c	Contact Disturbance (microseconds)	<5
Durability	IEC 512-9a	Circuit Resistance (mOhms)	<40
Mating/Unmating	IEC 512-13b	Mating Force (N)	<20
		Un-mating Force (N)	<20
Termination Cycles	IEC 352	Number of Cycles	>20

Electrical Test	Test Method	Measurement	Typical Test Results
Low Level Circuit Resistance	IEC 512-2a	Resistance (mOhms)	<20
Dielectric Withstand Voltage	IEC 512-4a	1000 V, 1 minute	Passed
Insulation Resistance	IEC 512-3a	Resistance (mOhms)	>500

Environmental	Test Method	Measurement	Typical Test Results
Temperature Life	IEC 512-9b	Circuit Resistance (mOhms)	<40
Humidity	IEC 512-11c	Circuit Resistance (mOhms)	<40
Thermal Shock	IEC 512-11d	Circuit Resistance (mOhms)	<40
Climactic Sequence	IEC 512-11a	Circuit Resistance (mOhms)	<40
Flowing Mixed Gas Corrosion	IEC 512-11g	Circuit Resistance (mOhms)	<40

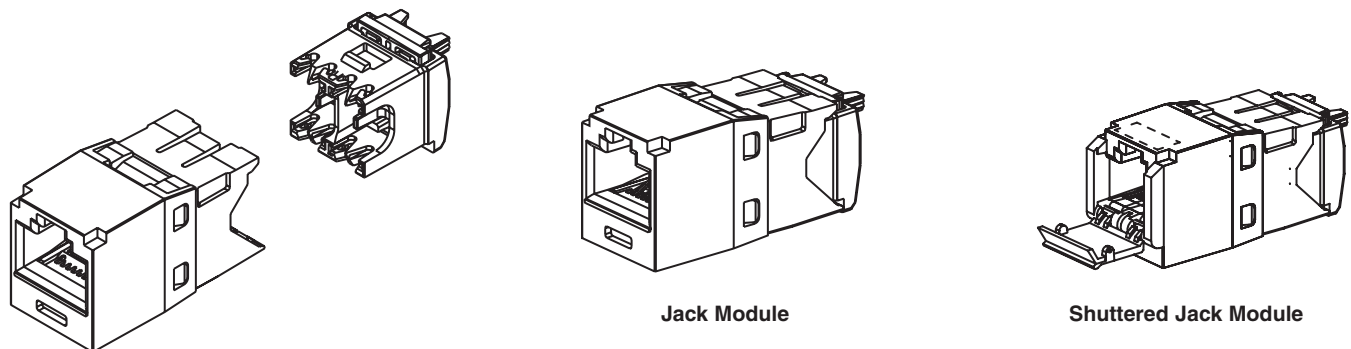

Jack Module

Shuttered Jack Module

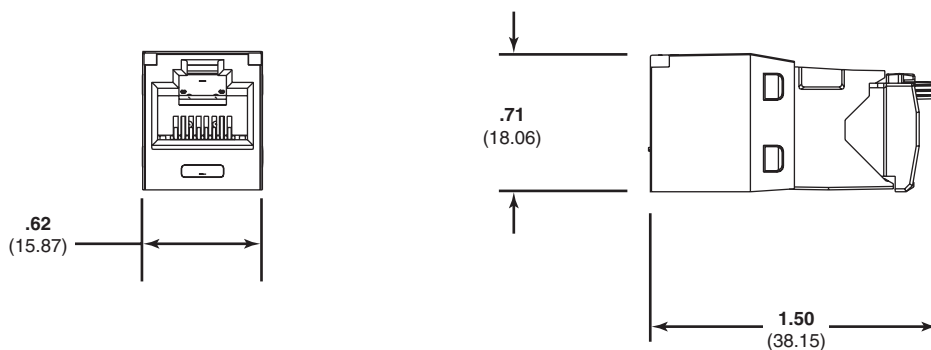

Dimensions are in inches (Dimensions in parenthesis are metric)

WORLDWIDE SUBSIDIARIES AND SALES OFFICES

PANDUIT CANADA
Markham, Ontario
cs-cdn@panduit.com
Phone: 800.777.3300

PANDUIT EUROPE LTD.
London, UK
cs-emea@panduit.com
Phone: 44.20.8601.7200

PANDUIT SINGAPORE PTE. LTD.
Republic of Singapore
cs-ap@panduit.com
Phone: 65.6305.7575

PANDUIT JAPAN
Tokyo, Japan
cs-japan@panduit.com
Phone: 81.3.6863.6000

PANDUIT LATIN AMERICA
Jalisco, Mexico
cs-la@panduit.com
Phone: 52.33.3777.6000

PANDUIT AUSTRALIA PTY. LTD.
Victoria, Australia
cs-aus@panduit.com
Phone: 61.3.9794.9020

For a copy of Panduit product warranties, log on to www.panduit.com/warranty

For more information

Visit us at www.panduit.com

Contact Customer Service by email: cs@panduit.com
or by phone: 800-777-3300 and reference COSP37

PANDUIT®

©2010 Panduit Corp.
ALL RIGHTS RESERVED.

WW-COSP37

6/2010